

NOTES:

1. DRAWING SHOWS TYPE 16 CATCH BASIN. TYPE E INLET STRUCTURE FILTERS ARE APPLICABLE FOR CATCH BASIN TYPE 1, 16, 17, AND 18 AFTER THE ROAD SURFACE COURSE IS PLACED.
2. PLACE CURB INLET FILTER AS SHOWN IN AREA WHERE SILT MAY SPILL OVER SIDEWALK AND CURB AFTER BASE IS PLACED.
3. CURB INLET FILTER WILL BE INSTALLED IN FRONT OF THE CURB INLET OPENING. THE FILTER WILL HAVE A MAXIMUM HEIGHT THAT DOES NOT COMPLETELY BLOCK THE INLET OPENING AND A MINIMUM LENGTH 2 FEET LONGER THAN THE LENGTH OF THE CURB OPENING. THIS WILL ALLOW FOR SUFFICIENT LENGTH TO COVER THE INLET WITH AT LEAST ONE FOOT BEYOND THE INLET ON BOTH ENDS.
4. THE FILTER WILL BE COMPOSED OF A UNIFORM FILTER FABRIC COVERING AN INTERNAL FILTER MATERIAL WHICH HAS COMPARTMENTS FOR STONE, SAND OR OTHER WEIGHTED MATERIALS, OR OTHER PHYSICAL MECHANISMS TO HOLD THE UNIT IN PLACE.
5. AS APPLICABLE, UTILIZE MECHANISMS AND/OR FILL AGGREGATE COMPARTMENTS TO A LEVEL THAT WILL KEEP THE SURFACE COURSE INLET FILTER IN PLACE AND CREATE A SEAL BETWEEN THE SURFACE COURSE INLET FILTER AND THE ROAD SURFACE.
6. THE UNIFORM FILTER FABRIC IS NON-BIODEGRADABLE AND RESISTANT TO DEGRADATION BY ULTRAVIOLET EXPOSURE AND RESISTANT TO CONTAMINANTS COMMONLY ENCOUNTERED IN STORM WATER. USE FILTER FABRIC THAT IS CAPABLE OF REDUCING EFFLUENT SEDIMENT CONCENTRATIONS BY NO LESS THAN 80% UNDER TYPICAL SEDIMENT MIGRATION CONDITIONS.
7. THE FILTER MATERIAL WILL ALLOW STORM WATER TO FREELY FLOW THROUGH WHILE TRAPPING SEDIMENT AND DEBRIS AND BE RESISTANT TO CONTAMINANTS COMMONLY ENCOUNTERED IN STORM WATER. STRAW BALES, PINE BALES, LEAF MULCH, AND GRASS CLIPPINGS ARE NOT PERMISSIBLE FILTER MATERIALS.
8. PONDING IS LIKELY IF SEDIMENT IS NOT REMOVED REGULARLY. INSPECTION OF CURB INLET FILTER SHOULD BE MADE EVERY SEVEN (7) CALENDAR DAYS. ANY NEEDED REPAIRS SHOULD BE HANDLED IMMEDIATELY. THE CURB INLET FILTER SHOULD BE CLEANED IF A VISUAL INSPECTION SHOWS SILT AND DEBRIS BUILT UP AROUND THE FILTER.
9. DO NOT COMPLETELY BLOCK INLET OPENING WITH THE CURB INLET FILTER.

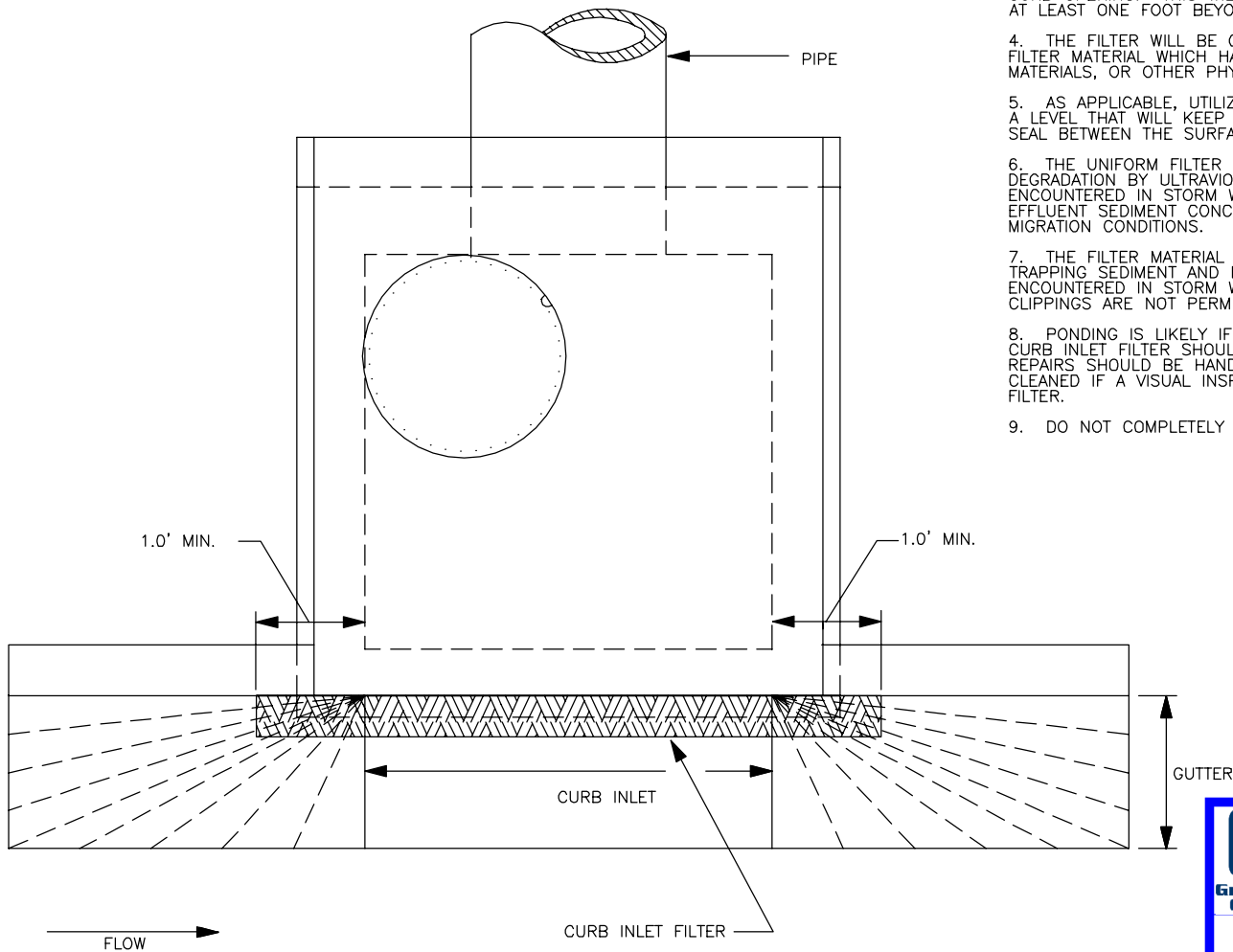

TOP VIEW



Greenville County  
Storm Water Management

INLET FILTER TYPE E

STANDARD DRAWING NO.

SC-07E

APPROVED BY: \_\_\_\_\_ DATE: January, 2018

GREENVILLE COUNTY STORM WATER MANAGEMENT

DATE