

MICROFILMED

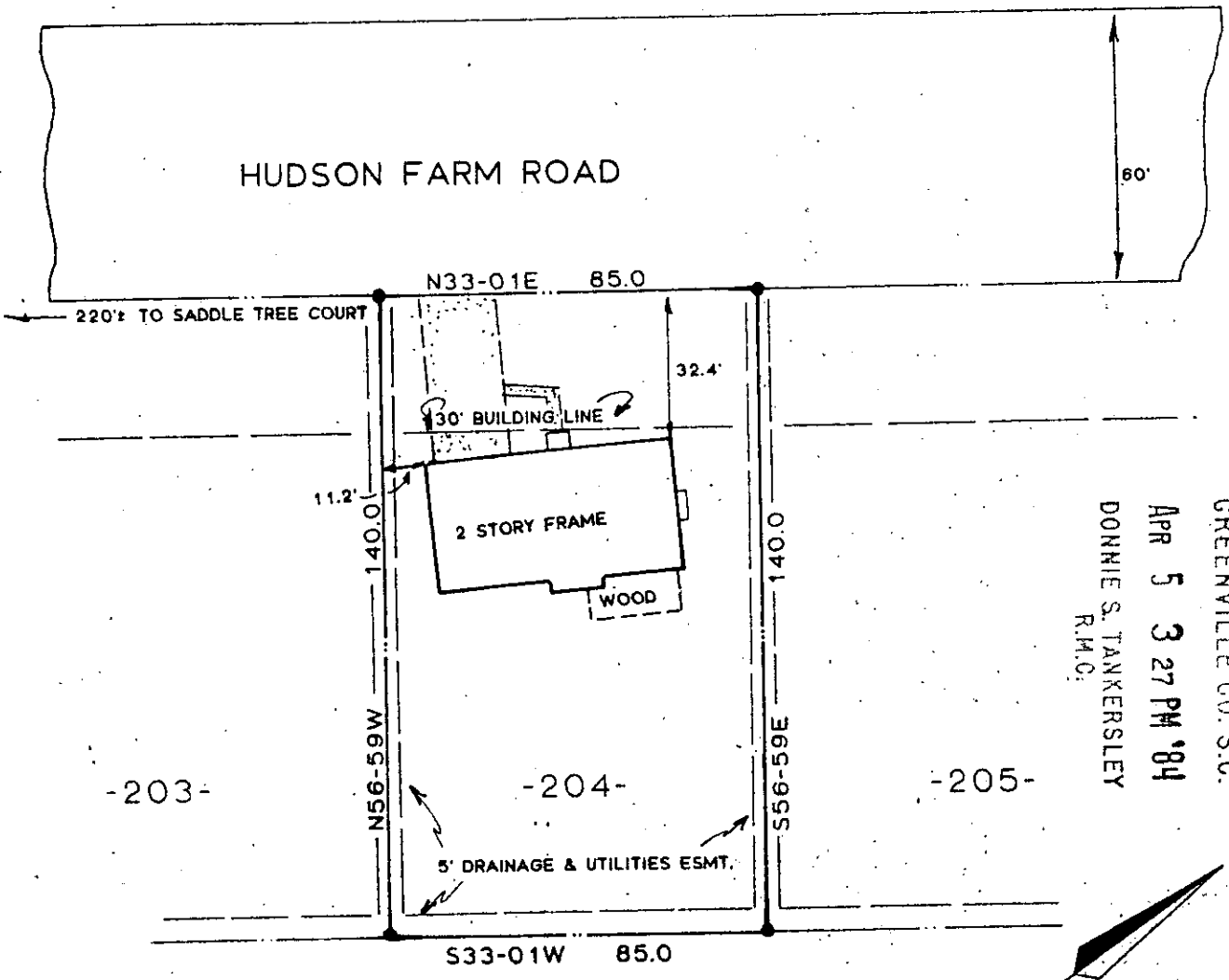

FILED  
 GREENVILLE CO. S.C.  
 APR 5 3 27 PM '84  
 DONNIE S. TANKERSLEY  
 R.M.C.

-203-

-204-

-205-

SECTION NO. 9  
 DEVENGER PLACE

31096

10-L-59

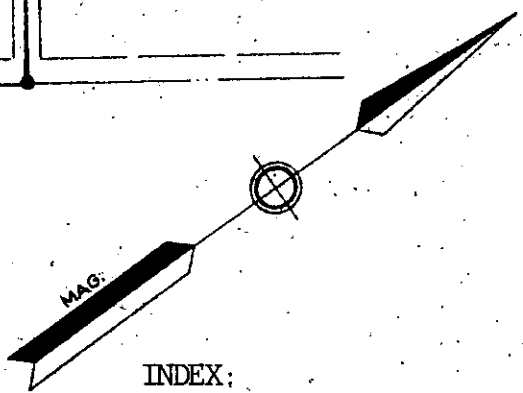

INDEX:  
 Noel W. Eckert and  
 Sharon D. Eckert  
 404 Hudson Farm Rd.  
 Greer, SC 29651

NOTES:

1. THIS DWELLING IS NOT LOCATED IN A FLOOD DISASTER AREA.
2. PROPERTY IS SUBJECT TO ANY AND ALL RIGHTS-OF-WAY AND EASEMENTS OF RECORD.

THIS IS TO CERTIFY THAT ON THE DATE SHOWN HEREON, I DID SURVEY THE ABOVE PROPERTY, THE SAME BEING KNOWN AND DESIGNATED AS LOT NO. 204 OF DEVENGER PLACE SECTION 11 AS SHOWN BY A PLAT RECORDED IN THE CLERK OF COURTS OFFICE FOR GREENVILLE COUNTY IN PLAT BOOK 7C AT PAGE 91. I FURTHER CERTIFY THAT THE PROPERTY LINES, STREETS, AND BUILDINGS ARE AS SHOWN ABOVE AND THAT THERE ARE NO ENCROACHMENTS EXCEPT AS SHOWN.

APRIL 3, 1984  
 DATE

*Robert R. Spearman*  
 ROBERT R. SPEARMAN REG. L. S. NO. 3615

TITLE NOEL W. ECKERT & SHARON D. ECKERT		LEGEND ● IRON PIN (OLD) ○ IRON PIN (NEW) △ NAIL & CAP □ AS NOTED	SEAL SOUTH CAROLINA REGISTERED PROFESSIONAL SURVEYOR ROBERT R. SPEARMAN 3615
GRAPHIC SCALE 20 0 40		3:00CD	
STATE SOUTH CAROLINA	COUNTY GREENVILLE	ROBERT R. SPEARMAN Post Office Box 8 Easley, South Carolina 29640 PH. 803-859-2308	
SCALE 1"=40'	DATE 04/03/84	REF. NO. 11689	033